

FRIDGCON[®]



F-23R / F-23F



F-49R / F-49F



F-72R / F-72F

QUALITY COMMERCIAL REFRIGERATION WITH STAINLESS STEEL INTERIOR & EXTERIOR DESIGN

Description:

- Stainless steel 430 exterior and interior with 304 stainless steel floor ensures maximum durability
- Self-closing door with stay-open feature
- Automatic interior lighting
- Door lock(s) with keys
- Recessed door handles
- Heavy-duty casters with 2 front lockable Casters
- Evaporator fan delay when door opens
- Environmentally friendly
- Quicker temperature recovery
- Top rated digital temperature control system
- Oversized refrigeration system for better performance



All Fridgcon Refrigeration Equipment are ETL Certified in the US & Canada, conforms to NSF / ANSI STD 7 Food Equipment Standard Sanitation

BOTTOM MOUNT SOLID DOOR REACH-IN DESCRIPTION
FRIDGCON BOTTOM MOUNT SERIES

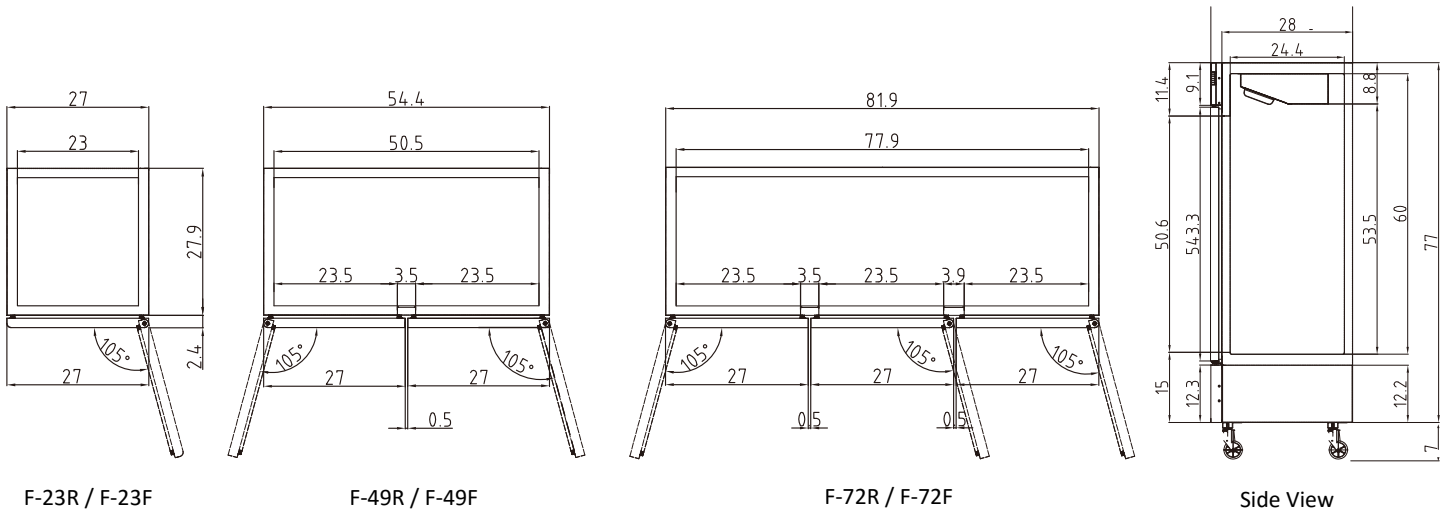

Model	F-23	F-49	F-72	F-23F	F-49F	F-72F
Unit Type	Bottom Mount Reach-In Refrigerator			Bottom Mount Reach-In Freezer		
Number of Doors	1	2	3	1	2	3
Capacity (Cu.Ft.)	23	49	72	23	49	72
Exterior Dimensions (in) LxWxH	27x31.5x82.2	54.4x31.5x82.2	81.9x31.5x82.2	27x31.5x82.2	54.4x31.5x82.2	81.9x31.5x82.2
Interior Dimensions (in) LxWxH	22.2x25.2x60	49.7x25.2x60	77.1x25.2x60	22.2x25.2x60	49.7x25.2x60	77.1x25.2x60
Shelf Dimensions (in)	20.9x24.4	20.9x24.4	20.9x24.4	20.9x24.4	20.9x24.4	20.9x24.4
Shelf Qty	3	6	9	3	6	9
Load Capacity Per Shelf (lbs)	155	155	155	155	155	155
Net Weight (lbs)	275	430	630	285	440	640
Voltage (v/hz/ph)	115/60/1	115/60/1	115/60/1	115/60/1	115/60/1	115/208~230/60/1
NEMA	5 - 15P	5 - 15P	5 - 15P	5 - 15P	5 - 15P	L14 - 20P
Cord Length ()	8	8	8	8	8	8
Power (W)	365	590	650	650	1170	1200
Power Consump on (kw/24h)	2	2.3	3.4	6.2	10	14.4
Compressor Power (hp)	1/4	1/3	1/2	1/2	3/4	1
Defrost Method	Air Defrost	Air Defrost	Air Defrost	Electric Defrost	Electric Defrost	Electric Defrost
Climate Types	5	5	5	5	5	5
Refrigerant Amount (oz)	9.2	13.4	19.7	13.4	19.4	25.4
Refrigerant	R-134a	R-134a	R-134a	R-404a	R-404a	R-404a
Cooling Method	Ven lated	Ven lated	Ven lated	Ven lated	Ven lated	Ven lated
Temperature (°)	33° to 45°	33° to 45°	33° to 45°	-8° to -1°	-8° to -1°	-8° to -1°
Insula on Thickness (mm)	60	60	60	60	60	60
Foaming Material	C ₅ H ₁₀	C ₅ H ₁₀	C ₅ H ₁₀	C ₅ H ₁₀	C ₅ H ₁₀	C ₅ H ₁₀
Shipping Information						
Packing Dimensions (in) LxWxH	28x32x84	55x32x84	82x32x84	28x32x84	55x32x84	82x32x84
Crated Weight (lbs)	310	510	680	315	515	685
Freight Class	150	150	150	150	150	150