

FRIDGCON®



FSU-27



FSU-48



FSU-60



FSU-72

QUALITY COMMERCIAL REFRIGERATION WITH STAINLESS STEEL INTERIOR & EXTERIOR DESIGN

Description:

- Stainless steel 430 exterior and interior with 304 stainless steel floor ensures maximum durability
- Self-closing door with stay-open feature
- 9-1/4" deep cutting board included
- Forced air refrigeration system
- Recessed door handles
- Heavy-duty casters with 2 front lockable Casters
- Evaporator fan delay when door opens
- Environmentally friendly
- Quicker temperature recovery
- Top rated digital temperature control system



All Fridgcon Refrigeration Equipment are ETL Certified in the US & Canada, conforms to NSF / ANSI STD 7 Food Equipment Standard Sanitation

SOLID DOOR SANDWICH / SALAD PREP TABLE DESCRIPTION

FRIDGCON SOLID DOOR SANDWICH / SALAD PREP TABLE SERIES

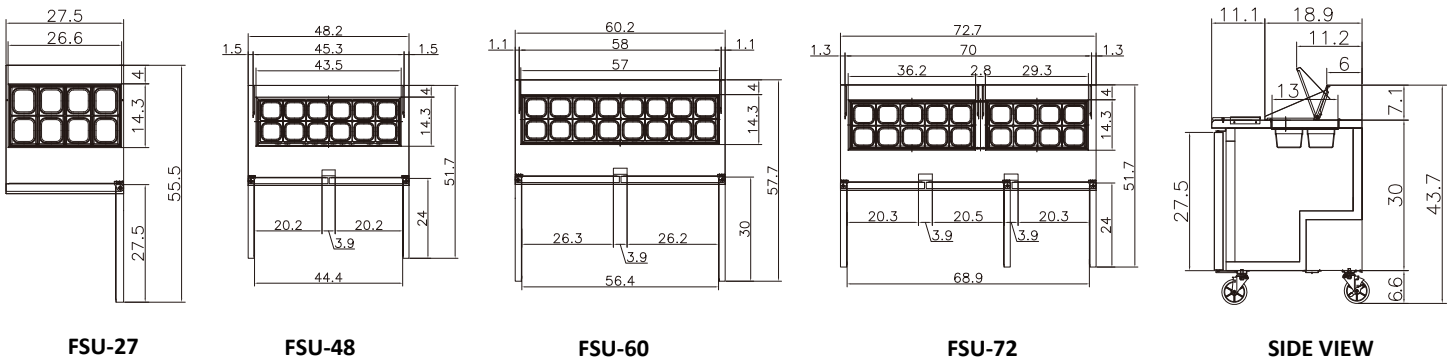

Model	FSU-27	FSU-48	FSU-60	FSU-72
Unit Type	Sandwich / Salad Prep Tables - Pans Not Included			
Number of Doors	1	2	2	3
Pan Capacity (1/6 Size)	8	12	16	18
Exterior Dimensions (in) LxWxH	27.5x30x43.7	48.2x30x43.7	60.2x30x43.7	72.7x30x43.7
Interior Dimensions (in) LxWxH	23.9x23.6x26.7	44.7x23.6x26.7	56.7x23.6x26.7	68.9x23.6x26.7
Shelf Dimensions (in) LxWxH	23.2x17.6x1.3	21.5x17.6x1.3	27.6x17.6x1.3	(2)21.5x17.6x1.3 (1)23.6x17.6x1.3
Shelf Qty (pcs)	1	2	2	3
Load Capacity Per Shelf (lbs)	155	155	155	155
Net Weight (lbs)	230	285	350	390
Voltage (v/hz/ph)	115/60/1	115/60/1	115/60/1	115/60/1
AMPS	4.2	6.5	6.5	7.5
NEMA	5 - 15P	5 - 15P	5 - 15P	5 - 15P
Cord Length (ft)	8	8	8	8
Power (W)	390	560	560	630
Power Consumption (kw/24h)	1.6	2.2	2.2	2.6
Compressor Power (hp)	1/4	1/3	1/2	1/2
Defrost Method	Air Defrost	Air Defrost	Air Defrost	Air Defrost
Defrost Power (w)	0	0	0	0
Climate Types	5	5	5	5
Refrigerant Amount (oz)	9.2	12.3	12.3	17.6
Refrigerant	R-134a	R-134a	R-134a	R-134a
Cooling Method	Ventilated	Ventilated	Ventilated	Ventilated
Temperature (°)	33° to 45°	33° to 45°	33° to 45°	33° to 45°
Insulation Thickness (mm)	45	45	45	45
Foaming Material	C ₅ H ₁₀	C ₅ H ₁₀	C ₅ H ₁₀	C ₅ H ₁₀
Shipping Information				
Packing Dimensions (in) LxWxH	29x32x45	50x32x45	62x32x45	74x32x45
Crated Weight (lbs)	260	320	390	440
Freight Class	150	150	150	150