

FRIDGCON®



FSU-27-12M



FSU-48-18M



FSU-60-24M



FSU-72-30M

QUALITY COMMERCIAL REFRIGERATION WITH STAINLESS STEEL INTERIOR & EXTERIOR DESIGN

Description:

- Stainless steel 430 exterior and interior with 304 stainless steel floor ensures maximum durability
- Self-closing door with stay-open feature
- 9-1/4" deep cutting board included
- Forced air refrigeration system
- Recessed door handles
- Heavy-duty casters with 2 front lockable casters
- Evaporator fan delay when door opens
- Environmentally friendly
- Quicker temperature recovery
- Top rated digital temperature control system



All Fridgcon Refrigeration Equipment are ETL Certified in the US & Canada, conforms to NSF / ANSI STD 7 Food Equipment Standard Sanitation

SOLID DOOR MEGA TOP SANDWICH / SALAD PREP TABLE DESCRIPTION
FRIDGCON MEGA TOP SANDWICH / SALAD PREP TABLE SERIES

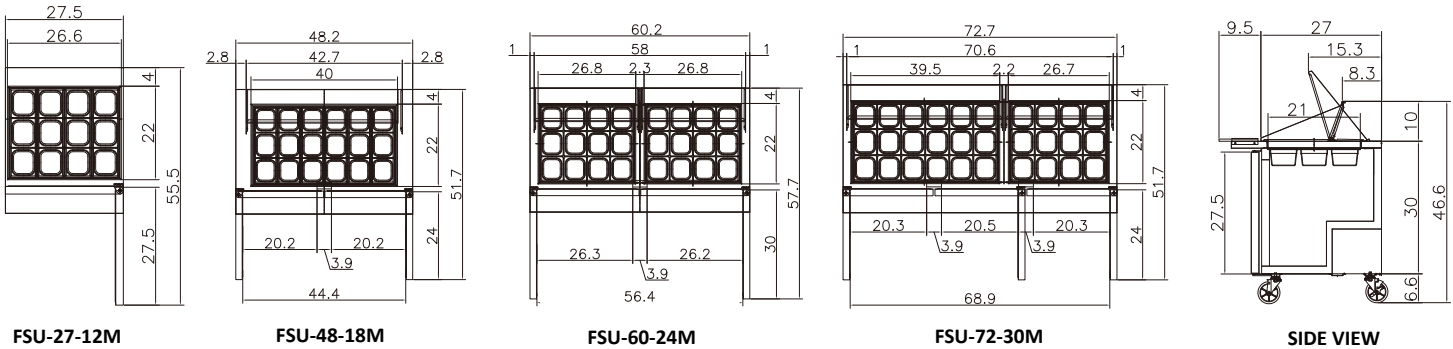

FSU-27-12M

FSU-48-18M

FSU-60-24M

FSU-72-30M

SIDE VIEW

Model	FSU-27-12M	FSU-48-18M	FSU-60-24M	FSU-72-30M
Unit Type	Salad - Sandwich Prep Tables - Mega Top - Pans Not Included			
Number of Doors	1	2	2	3
Pan Capacity (1/6 Size)	12	18	24	30
Exterior Dimensions (in) LxWxH	27.5x36.8x46.5	48.2x36.8x46.5	60.2x36.8x46.5	72.7x36.8x46.5
Interior Dimensions (in) LxWxH	23.9x23.6x26.4	44.7x23.6x26.4	56.7x23.6x26.4	69.1x23.6x26.4
Shelf Dimensions (in) LxWxH	23.2x17.6x1.3	21.5x17.6x1.3	27.6x17.6x1.3	(2)21.5x17.6x1.3 (1)23.6x17.6x1.3
Shelf Qty (pcs)	1	2	2	3
Load Capacity Per Shelf (lbs)	155	155	155	155
Net Weight (lbs)	240	290	360	420
Voltage (v/hz/ph)	115/60/1	115/60/1	115/60/1	115/60/1
AMPS	4.2	6.5	6.5	7.5
NEMA	5 - 15P	5 - 15P	5 - 15P	5 - 15P
Cord Length (ft)	8	8	8	8
Power (W)	390	560	560	630
Power consumption (kw/24h)	1.6	2.2	2.2	2.6
Compressor Power (hp)	1/4	1/3	1/2	1/2
Defrost Method	Air Defrost	Air Defrost	Air Defrost	Air Defrost
Defrost Power (w)	0	0	0	0
Climate types	5	5	5	5
Refrigerant Amount (oz)	9.2	12.3	12.3	17.6
Refrigerant	R-134a	R-134a	R-134a	R-134a
Cooling Method	Ventilated	Ventilated	Ventilated	Ventilated
Temperature (°)	33° to 45°	33° to 45°	33° to 45°	33° to 45°
Insulation Thickness (mm)	45	45	45	45
Foaming Material	C ₅ H ₁₀	C ₅ H ₁₀	C ₅ H ₁₀	C ₅ H ₁₀
Shipping Information				
Packing Dimensions (in) LxWxH	28x38x47	50x38x47	62x38x47	74x38x47
Crated Weight (lbs)	260	320	390	440
Freight Class	150	150	150	150